

NUOVA BRAVO 1.4 16v HEADLAMP/LIGHT CLUSTER LIGHT BEAM - POSITION 5540B38

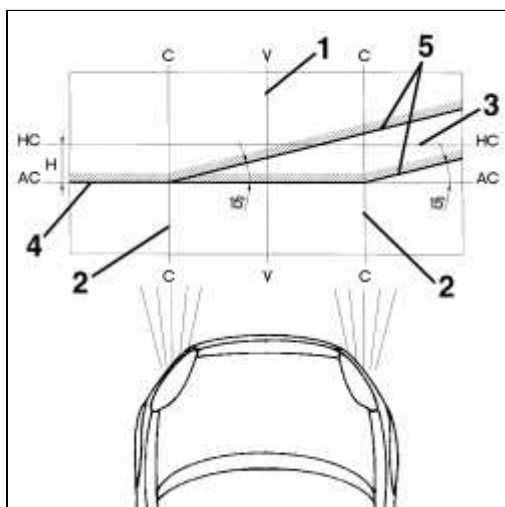

- Equip the vehicle with spare wheel, tools, fluids, fuel reserve and with the driver on board.

- Check that the tyre inflation pressure is correct.

- Place the headlamps in position "0" (only for vehicles not equipped with gas discharge headlamps).

- Place the vehicle on a flat surface, perpendicular to a screen with an opaque surface 10 metres away on which the following lines are traced.

1. V-V: vertical, corresponding to the trace of vehicle plane of symmetry.

2. C-C: lines drawn through vertical planes passing through the light cluster reference centres.

3. HC-HC: horizontal, corresponding to the ground clearance of the light cluster reference centres.

4. AC-AC: horizontal, 10 cm below the line HC - HC.

5. Lines inclined by 15° as illustrated in the diagram.

- Switch on the dipped headlamps.

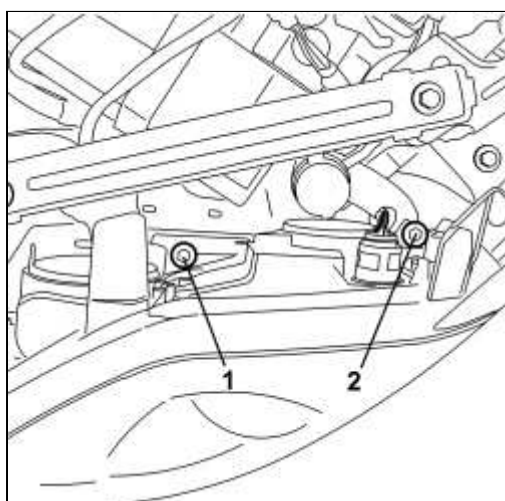

1. Vertical alignment. Adjust the vertical adjustment screw for the light cluster so that the horizontal section of the demarcation line between the dark zone and the area lit up by the light band is aligned with the line AC - AC traced on the screen.

2. Horizontal alignment. Adjust the horizontal adjustment screw for the light cluster so that the point where the two horizontal and inclined demarcation lines cross with the point where lines C - C and AC - AC cross on the screen is aligned.