

PURPOSE

To provide indications regarding the operation of the electronic control units for the "IAW P8 by PQP" multiple injection/ignition system and to define the methods of identifying faulty components.

COMPOSITION OF THE STANDARD

- **point 1** : composition of the system.
- **point 2** : system operation.
- **point 3** : functional checks and identification faulty components.
- **Annex 1** : system diagnosis characteristics.

This standard consists of 5 pages and 1 annex (see page 2)

Change	Date	Description
	Dec. '93	Edition 1 –New (RG)
A	Oct. '94	" " –Modified annex 1 for insertion of ELECTRONIC KEY (immobiliser) and corrected §A (RG)
B	Dec. '94	" " –Corrections made to drawing references and to Supplier Spare Parts Codes (RG)



Edition 1 Ch. B Code NPR -

CARTA RICICLATA 100% 100% RECYCLED PAPER

CONFIDENTIAL
THIS DOCUMENT MUST NOT BE REPRODUCED OR CIRCULATED TO THE THIRD PARTIES
WITHOUT PRIOR WRITTEN CONSENT BY FIAT AUTO S.P.A. IN CASE OF DISPUTE
THE ONLY VALID REFERENCE IS THE ORIGINAL ITALIAN EDITION

§ " A " – LIST OF ANNEXES

ANNEX No.	MODEL OF VEHICLE	ADDRESS	IDENTIFICATION CODE	DRAWING N°	SUPPLIER SPARE PARTS CODE
1	TIPO 200016V USA'83	address 10H on line L towards E.C.U. and line K towards Test Instrument	55 D0 02 92 91 4A●	7747420	61.600.106.00
	TIPO Maq 2000 16V		55 CE 85 01 94 3D●	46410953	61.600.209.04
	Nuova Delta 2000 16V		55 CE 85 01 94 3D●	46410953	61.600.209.04
	Nuova Delta 2000 16V T/C 4x2		55 CB 85 92 13 4A●	46416777	61.600.196.05
	COUPÈ ESSE 2.0 16V T/C		55 CB 85 9B 13 D3●	46416775	61.600.194.04
	Delta Evoluzione 2000 16V 4x4 USA'83		55 CD 85 26 13 E0 ●	46402178	61.600.216.02
	Coupè S 2.0		55 CE 85 83 94 BF★	46421171	61.600.193.02
	Coupè S 2.0 T/C		55 CB 85 01 94 BA★	46421165	61.600.194.05
	Nuova Delta 2.0		55 CE 85 04 94 40★	46421163	61.600.209.05
	Nuova Delta 2.0 T/C		55 CB 85 02 94 3B★	46421170	61.600.196.06
	Dedra 2.0 8V C.A.		55 3B 83 01 94 A8★	46423883	61.600.091.04
	Tempra 2.0 8V C.A.			46423883	61.600.091
	Tempra 2.0 8V mech. gear		55 38 83 01 94 25★	46423876	61.600.152.01
	Tempra 2.0 8V 4x4		55 38 83 02 94 26★	46423877	61.600.136.02
	Dedra 2.0 16V 4x4		55 CE 85 07 94 43★	46421168	61.600.235.01
	Dedra 2.0 16V		55 CE 85 08 94 C4★	46421167	61.600.215.01
	Alfa 155 2.0 16V 4x4		55 BC 83 01 94 29★	46421169	61.600.101.05

- Version without ELECTRONIC KEY (Immobiliser)
- ★ Version with ELECTRONIC KEY (Immobiliser).

1

COMPOSITION OF THE SYSTEM

The system is composed of the components listed below. The characteristics of these components are described in the relative procurement specifications also listed below:

Weber electronic injection/ignition control unit	P.S.	(CEL)
Absolute pressure sensor	P.S. 9.93241	(CEL)
Intake air temperature sensor	P.S. 9.93225	(CEL)
Engine coolant temperature sensor	P.S. 9.93225	(CEL)
High voltage distributor with built-in engine timing sensor	P.S. 9.93223	(CEL)
Engine rpm and TDC sensor	P.S. 9.93206	(CEL)
Throttle valve position sensor	P.S. 9.93228/02	(CEL)
Electric fuel pump in tank	P.S. 9.93227/01	(CEL)
Electroinjectors	P.S. 9.93231	(CEL)
Electromagnetic air valve	P.S. 9.93230/02	(CEL)
Ignition module	P.S.	(CEL)
Lambda sensor	P.S. 9.93233/50	(CEL)
Electric fuel pump control relay	P.S. 9.92210	(CEL)
Electronic unit supply relay	P.S. 9.92210	(CEL)
Fuel pressure regulator	P.S. 9.02240/01	(CME)
Ignition coils	P.S. 9.93261	(CEL)
Knock sensor	P.S. 9.93205	(CEL)

System diagram :

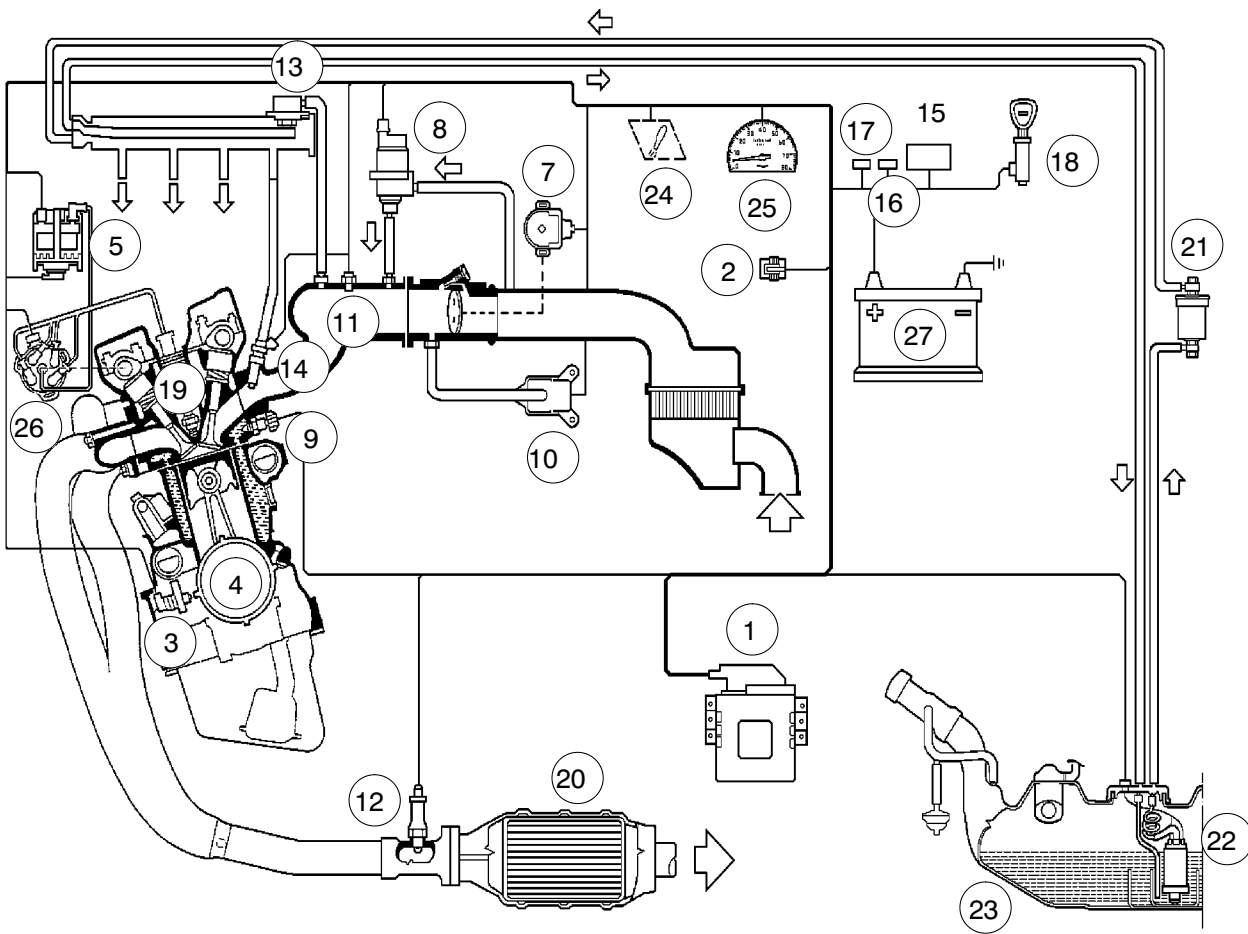

KEY

- 1) Electronic injection/ignition control unit
- 2) Diagnosis socket
- 3) RPM and TDC sensor
- 4) Engine pulley (four teeth)
- 5) Ignition coil with built-in power module
- 6) Throttle body
- 7) Throttle valve position sensor
- 8) Engine idle rpm regulation actuator (V.A.E.)
- 9) Engine coolant temperature sensor
- 10) Intake air absolute pressure sensor
- 11) Intake air temperature sensor
- 12) Lambda sensor
- 13) Fuel pressure regulator
- 14) Electroinjectors and fuel manifold
- 15) System power supply double relay
- 16) System fuse
- 17) Electronic control unit fuse
- 18) Key-operated ignition switch
- 19) Spark plugs
- 20) Catalytic converter
- 21) Fuel filter
- 22) Electric fuel pump
- 23) Fuel tank
- 24) Injection/ignition system malfunction warning light
- 25) Rev counter
- 26) High voltage distributor with built-in injection timing sensor
- 27) Battery

2

SYSTEM OPERATION

The P8 Family Weber–Marelli multiple injection/ignition system is a system employing a microprocessor–controlled digital injection termed " SPEED DENSITY LAMBDA " i.e. the angular speed, density of intake air, counter rotation control of the mixture ratio. In practise this system uses the engine rpm and the air density to measure the quantity of air drawn in by the engine itself.

The sensors present in the system make it possible to correct the basic strategy for all conditions of engine operation.

The density of the air drawn in by the engine is calculated on the basis of absolute pressure and temperature of the air, both measured in the intake manifold.

Once the quantity of the air has been established, the quantity of fuel is metered on the basis of the mixture ratio required.

The quantity of air drawn in by each cylinder, for each engine cycle, mainly depends on:

- Intake air density
- Unit displacement
- Volumetric efficiency

Volumetric efficiency is determined experimentally on the engine across the entire range of engine operation (rpm and loading) and is stored in a map of the electronic control unit

The injectors are commanded sequentially and are timed on per cylinder. The injectors are commanded in accordance with the intake sequence while delivery (for each cylinder) may be moved with a certain injection advance starting from the expansion phase up to the intake phase already underway.

The timing of the start of delivery is contained in a map of the electronic control unit.

Ignition is of the induction discharge type with conduction time control controlled by a power module coupled to the ignition coil.

The engine rpm and the density of the intake air also make it possible to calculate the optimal ignition advance for all operating conditions.

The stoichiometric air–fuel ratio in this system must be kept as precise as possible to permit a correct and lasting operation of the catalytic silencer and thus to reduce pollutant emissions.

Stoichiometric metering is also obtained with the aid of a lambda sensor of the pre–heated type. This sensor, by a constant analysis of the quantity of oxygen contained in the exhaust gases, alerts the electronic control unit which is able to make real–time corrections to the mixture ratio (air–fuel) when this is not stoichiometric by instantaneously metering the fuel to be injected through the injectors.

This is the reason for which the system is termed " SPEED DENSITY LAMBDA ".

The control unit is able to :

Manage the frequency and time of injection; i.e. provide the quantity of fuel, calculated for each cylinder with a command of the sequential type timed 1–3–4–2 in a single delivery.

Electronically control the moment of ignition by the coil and power module)

Check the air delivery at idle rpm by the V.A.E. in order to permit regular operation of the engine when the ambient parameters and load applied change.

Through the execution of particular diagrams, **detect any operating defects of the various sensors**, recorded in the RAM memory and **replace the erroneous data or data not achieved with replacement values** in order to ensure continuous operation of the engine even under emergency conditions (RECOVERY) and alerting the driver of the emergency situation by switching in the instrument panel the warning light on.

The vehicle will not function if a serious defect is present in one of the following parts:

- RPM and TDC sensor
- power module and ignition coil
- fuel pump
- electroinjectors
- control unit power supply fuses or circuits.

Provide the data relative to operating defects detected and stored via the serial line (serial socket) of the Test Instrument (e.g. Fiat/Lancia/Tester), if connected.

Store and, over a period of time, adapt the vehicle parameters, i.e. modify or maintain a corrective factor for the injection time in the memory which influences the mixture ratio via the signal coming from the lambda sensor (SELF–ADAPTATION function)

Possibility to be connected to the ELECTRONIC KEY (Immobiliser) control unit

Once the customisation procedure has been completed for the vehicle (memorisation of the keys) the engine control unit **must** be connected to the electronic key control unit with which customisation was carried out.

“The Immobiliser system prevents the engine from being started unless one of the keys (fitted with a Transponder)” memorised by the immobiliser control unit is used.

As soon as the ignition key has been turned to the “MARCIA” position, an exchange of information occurs between the engine control unit and the immobiliser control unit; if the procedure has a positive outcome, the engine control unit permits starting, if not prevents it.

The communication exploits a serial line which connects the two control units.

3

FUNCTIONAL CHECKS AND IDENTIFICATION OF FAULTY COMPONENTS

3.1

The correctness of the electrical/pneumatic connections and the presence of system anomalies is checked using the testing procedure below.

A full control is only carried out when the engine is running at idle as specified in Process Standards 3.46089 and 3.00093.

3.2

Engine testing – diagnosis procedure (full check)

This operation must be carried out using the testing equipment for which provision is made during production for electronic control units of FIATxxx.(yyyy) design or with the aid of the FIAT – LANCIA Tester where the necessary modifications have not been made or the above equipment is not present.

3.2.1

Contact the following department to obtain the “Customised memory module” for the control unit and relative testing procedures

D.T. – Sistemi ed Impianti Elettrici ed Elettronici – Metodologie e Testing – Diagnosi

4
DIAGNOSIS CHARACTERISTICS OF SYSTEM

4.1
DIAGNOSIS TABLE

SYSTEM SUB-GROUP	ASSISTANCE PERFORMANCE OBTAINED BY CONNECTING THE TEST INSTRUMENT TO THE DIAGNOSIS SOCKET, WITH CONTROL UNIT POWERED AND FUNCTIONING	P O	C K	E R	V R	NOTES
CONTROL UNIT	Identification of the system with ISO code (transmitted by control unit at power on)	*				<p><u>Communication protocol with Test Instrument :</u> The data are coded and transmitted in NRZ with positive logic at a speed of 7812.5 baud. Writing of the byte is as follows : 1 start bit ("0") 8 datum bits, 1 stop bit ("1") no parity. At a power on the control unit transmits 6 bytes of the cap code at 1200 baud. Successive to this the control unit sets itself for the dialogue with the Test Instrument at a speed of 7812.5 baud The communication is bi-directional and takes place on line "L" from Test Instrument to control unit (transmission of data request codes), and on line " K " from the control unit to the Test Instrument (transmission of data requested).</p> <p><u>Data transmitted:</u> transmitted following request from the Test Instrument; 9 error bytes (three UNIRAM and three CUNIEEP in volatile memory, three UNIEEP in permanent memory), 16 bytes of error age counter, 4 status bytes, 13 engine parameters (engine rpm, injection time, ignition advance, pressure, water temp, air temp. throttle valve angle, battery voltage, equivalent position of physical trimmer, electronic RAM trimmer position, lambda sensor correction integrator, injection timing angle, electromagnetic air valve duty cycle), the ISO code (6 status bytes) and the supplier spare part code (10 status bytes plus 1 end of code byte).</p> <p><u>Recognition of faults:</u> This is managed within the basic function relative to each component.</p> <p><u>Memorisation of the errors:</u> If an error is detected on a line, starting from the OK status, a filter procedure is activated which consists of sampling the line for a T1 time. If, at the end of T1, the number of erroneous samples exceeds a set value Q1, the filter stage is passed and the error is written in the volatile RAM (if, on the other hand, the filter stage is not passed, it returns to the OK state).</p>
	Identification of the control unit with spare parts code (transmitted upon request from the Test Instrument) Connection validity check between Test Instrument and Control Unit Visualisation of : – duration of calculated injection pulse (resolution : 4µs/bit) – calculated ignition advance (resolution : 0.255/bit) – actuated injection timing angle (conversion formula : $\alpha = 7205 - \text{DATUM} * 905/4$) – battery voltage (resolution: 62.8 mV/bit) – equivalent position of physical trimmer of mixture ratio calibration (range 0 to 255 bit) – RAM trimmer position of mixture ratio calibration (range 0 to 255 bit) Signalling of : – recognition of signal panel – state of mixture ratio regulation (self-adaptation activated or RAM trimmer activated) in EPROM and E ² PROM continued	*	*	*	*	

KEY: PO = KEY ON - CK = STARTING - ER = ENGINE RUNNING - VR = VEHICLE MOVING

Fiat Auto
normazione

WEBER - MARELLI MULTIPLE INJECTION/IGNITION SYSTEM
P8 by PQP Family
System operation and faulty components identification in the models (See § A)

3.00608
ANNEX 1
Page: 1/16

Edition	1	Ch.	A	Code	NPR
---------	---	-----	---	------	-----

DIAGNOSIS TABLE continued

SYSTEM SUB-GROUP	ASSISTANCE PERFORMANCE OBTAINED BY CONNECTING THE TEST INSTRUMENT TO THE DIAGNOSIS SOCKET, WITH CONTROL UNIT POWERED AND FUNCTIONING	P O	C K	E R	V R	NOTES
CONTROL UNIT	<p>Self-diagnosis of components :</p> <p>RAM memory writing error</p> <p>ROM memory checksum error</p> <p>EEPROM memory writing error</p>	*	*	*	*	<p>In this state the malfunction warning light does not come on, as the error must still be validated. After the filter has been passed, a <u>validation</u> procedure is activated which consists of sampling the line for a T2 time. If the number of erroneous samples exceeds a set value Q2 the error validation stage is passed and the error is written in the permanent EEPROM; only after this operation will the warning light come on.</p> <p>If the error validation procedure is not passed, the contents of the RAM are erased and a return is made to the OK state (validation of good state). The values T1, Q1, T2, Q2 are calibration values specific for each line. Some particularly "serious" errors do not fall under the algorithm described and are validated immediately as soon as they are detected and stored in the permanent memory; for this type of error the malfunction warning light is illuminated immediately.</p> <p><u>Management of the error age counter:</u> Each line being tested is associated with an error counter which, at the initial validation of the fault, is placed at a fixed calibration value. This counter is decreased each time that 6 minutes pass without the error being validated again from the moment of the power on. When the counter reaches 0, if another 6 minutes have passed from the subsequent power on with no validation occurring, the error is deleted from the permanent EEPROM.</p> <p><u>Deletion of the errors in the permanent memory:</u> This is carried out following a specific command from the Test Instrument or automatically by the control unit when the error age counter reaches the value 0 (see "management of the error age counters").</p> <p><u>Active diagnosis:</u> This is carried out by the Test Instrument on the fuel pump, on the injectors (in sequence or individually), on the power module and on the VAE.</p> <p>It is also possible:</p> <ul style="list-style-type: none"> - as an alternative to the self-adaptation of the mixture ratio at idle, to regulate the CO by acting on the electronic trimmer housed in the control unit and activating a special procedure via the Test Instrument. - activate a rapid memorisation procedure of the self-diagnosis parameters via the Test Instrument.

KEY: PO = KEY ON - CK = STARTING - ER = ENGINE RUNNING - VR = VEHICLE MOVING

3.00608

Page 2
Change

Annex 1

PUBLISHED BY SATIZ S.p.A. NORMATIZIONE

DIAGNOSIS TABLE continued

SYSTEM SUB-GROUP	ASSISTANCE PERFORMANCE OBTAINED BY CONNECTING THE TEST INSTRUMENT TO THE DIAGNOSIS SOCKET, WITH CONTROL UNIT POWERED AND FUNCTIONING	P O	C K	E R	V R	NOTES
CONTROL UNIT						<p><u>Management of the malfunction warning light</u> :</p> <p>The illumination of the malfunction warning light is subordinate to the validation of the error. In this state the error flag is present at the same time both in the volatile and permanent memory. The warning light only comes on if the error is actually present.</p> <p>For the errors with immediate validation the illumination of the warning light is also immediate; if the good state of the line is revalidated the warning light will stay on for 510 engine rpm.</p> <p><u>NOTE</u> : If an error is present and the warning light is on, maximum engine rpm is limited to 4,000 to avoid the catalytic converter being damaged owing to the state of malfunction affecting the system.</p>
ABSOLUTE PRESSURE SENSOR Resistance bridge	<p>Visualisation of : Absolute pressure in the intake manifold Transfer function : $DATUM * 2.8758 + 91$ (mmHg)</p> <p>Signalling of : Pressure out of permitted range (if $p < 99.78$ mmHg sensor in s.c. to GND; if $p > 804.26$ mmHg sensor in o.c.)</p> <p>Signalling of : Incongruity between the pressure value measured by the sensor and that calculated with the partialisation function. This function describes the relation between the pressure upstream and downstream of the throttle valve on the basis of the throttle valve angle and engine rpm.</p>	★	★	★	★	<p><u>Working range of the sensor</u> :</p> <p>127.5 ÷ 787.7 mmHg</p> <p><u>Recovery</u> (with no error on the throttle valve sensor): The recovery values for the pressure are determined on the basis of the partialisation function.</p> <p><u>Recovery with error present on throttle valve sensor</u> : A single recovery value is selected.</p>
ENGINE RPM SENSOR (with variable reluctance)	<p>Visualisation of : Engine rpm (engine period 180°, resolution 1 µs/bit) Transfer function : $30 * 10^6 / DATUM$ (RPM)</p> <p>Signalling of : - o.c. - s.c. to GND and loss of sequence</p>	★	★	★	★	<p>The pulse generator coupled to the sensor is of the 4-tooth type.</p> <p>The loss of sequence and the open circuit are detected by comparison with the engine timing signal; signalling of this type of error on the engine rpm sensor is subordinate to the absence of simultaneous failure on the engine timing sensor.</p>

KEY: PO = KEY ON - CK = STARTING - ER = ENGINE RUNNING - VR = VEHICLE MOVING

Fiat Auto

Annex 1

Page 3
Change

3.00608

PUBLISHED BY SATIZ S.p.A. NORMATIZIONE

DIAGNOSIS TABLE continued

SYSTEM SUB-GROUP	ASSISTANCE PERFORMANCE OBTAINED BY CONNECTING THE TEST INSTRUMENT TO THE DIAGNOSIS SOCKET, WITH CONTROL UNIT POWERED AND FUNCTIONING	P O	C K	E R	V R	NOTES
ENGINE TIMING SENSOR (with variable reluctance)	Signalling of : - o.c. - s.c. to GND and loss of sequence	*	*	*	*	A cam with two teeth angled at 90° to each other machined onto the high voltage distributor is coupled with the sensor. The loss of sequence and the open circuit are detected by comparison with the engine rpm signal; signalling of this type of error on the engine rpm sensor is subordinate to the absence of simultaneous failure on the engine rpm sensor. <u>Recovery</u> : Carried out by reconstruction of the cam signal on the basis of the reading of the engine rpm signal.
WATER TEMPERATURE SENSOR (NTC sensor)	Visualisation of : Temperature value read by the control unit The transfer function can be obtained from the table) Signalling of : Temperature out of permitted range (if Water T < -40°C, sensor in o.c.; if Water T > +125°C, sensor in s.c. to GND).	*	*	*	*	<u>Angle of operation</u> : -55°C ÷ +125 °C; <u>Recovery</u> (with no simultaneous error on air T sensor) if Air T < 30°C, the Air T value is used if Air T > 30°C, Water T is placed at 90°C. <u>Recovery in the presence of simultaneous error on Air T sensor</u> : Water T is placed = 90°C.
AIR TEMPERATURE SENSOR (NTC sensor)	Visualisation of : Temperature value read by the control unit La Transfer function can be obtained from the table) Signalling of : Temperature out of permitted range (if Air T < -40°C, sensor in o.c.; if Air T > +125°C, sensor in s.c. to GND).	*	*	*	*	<u>Range of operation</u> : -55°C to +125 °C; <u>Recovery</u> (with no simultaneous error on water T sensor) if T water < 47°C, Air T = Water T if Water T > 47°C, Air T = 47°C. <u>Recovery in the presence of simultaneous error on Water T sensor</u> : Air T is placed = 47°C.
THROTTLE VALVE POSITION SENSOR (potentiometer sensor)	Visualisation of : Angular position value read by control unit Transfer function is : for $\alpha < 30^\circ$: $\alpha = \text{DATUM} * 0.1848^\circ - 1.41^\circ$; for $31^\circ < \alpha > 89^\circ$: $\alpha = \text{DATUM} * 0.7058 - 90^\circ$ Signalling of : - throttle angle out of permitted range : if < 0°, sensor in s.c., if > 88.6° sensor in o.c. - state of throttle valve at idle or wide open.	*	*	*	*	<u>Range of sensor operation</u> : 05 to 85° <u>Maximum excursion</u> : 90° <u>Recovery</u> : this is selected on a table with 16 values on the basis of the pressure. <u>State of throttle valve at idle</u> : < 1.5° <u>State of throttle valve when wide open</u> : depends on the engine rpm .

KEY: PO = KEY ON - CK = STARTING - ER = ENGINE RUNNING - VR = VEHICLE MOVING

3.00608

Page 4
Change

Annex 1

PUBBLISHED BY SATIZ S.p.A. NORMAZIONE

DIAGNOSIS TABLE continued

SYSTEM SUB-GROUP	ASSISTANCE PERFORMANCE OBTAINED BY CONNECTING THE TEST INSTRUMENT TO THE DIAGNOSIS SOCKET, WITH CONTROL UNIT POWERED AND FUNCTIONING	P O	C K	E R	V R	NOTES
OXYGEN SENSOR (λ SENSOR)	Visualisation of : State of regulation of the mixture ratio (open/closed loop) Integral correction factor (range ± 1600, Transfer function $\mp 0.00125 * \text{DATUM}$ Signalling of : absence of communication from the λ sensor (disconnected sensor, in s.c. to Batt.V or malfunctioning).			* * *	* *	<u>Recovery for all failures affecting the sensor</u> : operation in Open Loop. If the sensor's heater does not work this is signalled as an error affecting the sensor itself.
INJECTORS	Activation of the injectors in sequence after command from the Test Instrument for 2 ms every second for 5 times. Activation of a single injector after command from the Test Instrument for 2 ms every second for 5 times.	* *				
IGNITION MODULE	Activation of coil 1, after command from the Test Instrument for 2 ms every second for 5 times.	*				
ELECTROMAGNETIC AIR VALVE	Visualisation of : activation duty cycle. The Transfer function is: (DATUM / 255) % duty cycle Activation , after command from the Test Instrument for 25 ms ON and 25 ms OFF for 5 times.	*	*	*	*	Duty Cycle < 26% (for Battery V of 12V) : valve completely closed Duty Cycle > 80% (for Battery V of 12V) : valve completely open
FUEL PUMP	Activation of the fuel pump piloting relay for 30 secs. after command from Test Instrument.	*				

KEY: PO = KEY ON - CK = STARTING - ER = ENGINE RUNNING - VR = VEHICLE MOVING

Fiat Auto

Annex 1

Page 5
Change

3.00608

CONFIDENTIAL

THIS DOCUMENT MUST NOT BE REPRODUCED OR CIRCULATED TO THE THIRD PARTIES
 WITHOUT PRIOR WRITTEN CONSENT BY FIAT AUTO S.P.A. IN CASE OF DISPUTE
 THE ONLY VALID REFERENCE IS THE ORIGINAL ITALIAN EDITION

PUBLISHED BY SATIZ S.p.A. NORMATIZIONE

DIAGNOSIS TABLE continued

SYSTEM SUB-GROUP	ASSISTANCE PERFORMANCE OBTAINED BY CONNECTING THE TEST INSTRUMENT TO THE DIAGNOSIS SOCKET, WITH CONTROL UNIT POWERED AND FUNCTIONING	P O	C K	E R	V R	NOTES
ELECTRONIC KEY (OR IMMOBILISER) (only where applicable)	Visualisation of : – immobiliser status error byte value <u>in RAM</u> – Immobiliser status error byte value <u>in E²PROM</u> – error age counter byte value Signalling of : – no code received or link interrupted – code unknown or not recognised – erroneous key code transmitted by immobiliser	* * * * * *	* * * * * *	* * * * * *	* * * * * *	<u>Conditions of error detection :</u> – no code received or link interrupted: this may occur when there is an open circuit or a s.c. to Batt V or a s.c. to GND, or if the immobiliser does not respond to any of the codes (when the engine control unit and the immobiliser control unit are virgin and an error is present on the immobiliser). – unknown or not recognised code: when the immobiliser transmits a code which is different from that the control unit expects to receive. – erroneous key code transmitted by the immobiliser: when the antenna is disconnected or if a key which has not been stored or a mechanical key is inserted. <u>Malfunction warning light</u> : ON <u>Recovery</u> : – The control unit is in " prohibit engine management ". i.e. the vehicle cannot be started. Recovery is possible using the Test Instrument via the appropriate command. <u>Environmental parameters</u> : State of immobiliser and battery voltage

KEY: PO = KEY ON – CK = STARTING – ER = ENGINE RUNNING – VR = VEHICLE MOVING

3.00608
 Page 6
 Change
 Annex 1

PUBLISHED BY SATIZ S.p.A. NORMATIZIONE

4.3

Line configuration and initialisation

4.3.1

Used lines

Configuration with line " K " towards Test Instrument, line " L " towards E.C.U. and initialisation at " Key on ".

4.3.2

Initialisation

No initialisation is required as the control unit is free–running (i.e. the ISO code is transmitted when the key is turned to ON).

4.3.3

ISO code

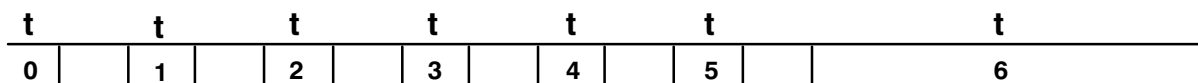

For a description of the ISO code for the relative models, refer to § A.

4.3.4

Time schedule

- Time between initialisation and preamble : **t₀ < 2 s**
- Time between bytes of the preamble : **t₁ < 1.2 s**
- t₂ < 1.2 s**
- t₃ < 1.2 s**
- t₄ < 1.2 s**
- t₅ < 1.2 s**
- t₆ = 500 ms.**

NOTE : The ISO code relative to the preamble is supplied by FIAT AUTO.

4.4

Communication

4.4.1

Communication parameters

The transmission logic is **positive**.
The coding of the datum occurs in **NRZ**, and the baud rate is **7812.5 Baud**.

- Start bit (" 0 ") : 1**
- Status bits : 8**
- Stop bit (" 1 ") : 1**

4.4.2

Type of communication

The control unit transmits on communication line " K " and receives on line " L " with a communication protocol of the question and answer type.

Communication :

Test Instrument> " L "> E.C.U.
E.C.U.> " K "> Test Instrument.

End of diagnosis dialogue.

Switching off the engine.

CARTA RICICLATA 100% 100% RECYCLED PAPER

CONFIDENTIAL
THIS DOCUMENT MUST NOT BE REPRODUCED OR CIRCULATED TO THE THIRD PARTIES
WITHOUT PRIOR WRITTEN CONSENT BY FIAT AUTO S.P.A. IN CASE OF DISPUTE
THE ONLY VALID REFERENCE IS THE ORIGINAL ITALIAN EDITION

4.4.3

List of parameters which can be requested to the ECU and conversion of the values

4.4.3.1

Control unit without ELECTRONIC KEY (Immobiliser)

VALUE	REQUEST CODE (HEX.)	CONVERSION	BYTE
Engine period (Msb)	01	30000000 / DATUM [RPM]	xx
Engine period (Lsb)	02		
Duration of injection (Msb)	03	4 * DATUM / 10 ³ [ms]	xx
Duration of injection (Lsb)	04		
Ignition advance	05	DATUM 11 / 4 [°Ang]	x
Intake pressure	06	DATUM * 6.4161 + 45.63 [mmHg] Turbo DATUM * 2.8758 + 91 [mmHg] Intake	x
Air temp.	07	Air/Water table [°C]	x
Water Temperature	08	see paragraph 4.5.3	x
Throttle valve angle	09	(DATUM*0.1848) - 1.41 [°degrees] if < 30 (DATUM * 0.7058) - 90 [°degrees] if ≥ 30	x
Battery voltage	0A	DATUM * 0.0628 [Volt]	x
Position of trimmer	0B	DATUM - 128	x
Injection timing angle	0C	720 - (DATUM * 90) / 4 [degrees]	x
VAE Duty cycle	0D	DATUM * 100/255 [%] see note ①	xx
UNIRAM 1	0F	See paragraph 4.4.4	x
UNIRAM 2	10		
UNIRAM 3	11		
Lambda correction integrator (Msb)	12	INT * 125 / 1000000 [%]	xx
Lambda correction integrator (Lsb)	13		
State of lambda strategy (FLGSMA)	14	see note ②	x
UNIRAM S	15	See paragraph 4.4.4	x
CUNEEP1	16		x
CUNEEP2	17		x
CUNEEP3	18		x
TRIMRAM	19	00h = -127, 80h = 00, FFh = +127	x
Activation of EPROM self-adaptation	1B	FABEPAT byte see note ③	x
Activation of EEPROM self-adaptation	1C	FABEEAT byte see note ④	x
UNIEEP1A	1D	See paragraph 4.4.4	x
UNIEEP2A	1E		x
UNIEEP3A	1F		x

continued

continued **List of parameters which can be requested to the ECU and conversion of the values**

VALUES	REQUEST CODE (HEX.)	CONVERSION	BYTE
Throttle valve sensor error counter	20	HEX	20
Pressure sensor error counter	21		
λ sensor error counter	22		
Water temperature sensor error counter	23		
knock sensor error counter	24		
Air temperature sensor error counter	25		
Mixture ratio error counter	26		
Error counter on VAE	27		
Engine rpm sensor error counter	28		
RAM memory error counter	29		
Digimatic signal error counter	2A		
N/D signal error counter	2B		
EEPROM error counter	2C		
EPROM error counter	2D		
Sequence error counter	2E		
Cam error counter	2F		
ISO CODE	30/35	DATUM	6
Supplier spare part code	36/40	DATUM ASCII + ETX (O3)	11

Note :

- ① The minimum and maximum values of the VAE activation DUTY CYCLE are : 18% (12h) and 94 % (5Bh).
- ② **FLGSMA** = Bit 7 at 1 (**80h**) => closed loop.
- ③ **FABEPAT**= Bit 7 at 1 (**80h**) => self-adaptation activated, Bit 6 at 1 (**40h**) => idle self-adaptation activated in **EPROM**.
- ④ **FABEEAT**= Bit 7 at 1 (**80h**) => self-adaptation activated, Bit 6 at 1 (**40h**) => idle self-adaptation activated in **EEPROM**.
- ⑤ The error memory bytes are :
UNIRAMx (Temporary error bytes in RAM)
CUNEEXPx (Copy of UNIRAMx for writing in EEPROM)
UNIEEXPx (Copy of CUNEEXP for writing in EEPROM)
- ⑥ For the management of the error counters, see paragraph 4.5.4.

4.4.3.2

Control unit with ELECTRONIC KEY (Immobiliser)

VALUES	REQUEST CODE (HEX.)	CONVERSION
Those described in point 4.4.3.1 plus the following	xx	See point 4.4.3.1
ELECTRONIC KEY status/error byte in RAM (UNIVAS)	71	See point 4.4.4.1
ELECTRONIC KEY status/error byte in EEPROM (EEVAS)	72	See point 4.4.4.2
ELECTRONIC KEY error age counter (CRDVAS)	73	See point 4.4.4.3

4.4.4

Status and error byte decoding

Byte	Decoding
UNIRAM1 CUNEEP1 UNIEEP1	1 VAE blocked open or closed
	2 Mixture ratio at limit of range
	3 Air temperature sensor
	4 Knock
	5 Water temperature
	6 Lambda sensor disconnected or faulty
	7 Pressure sensor
	8 Throttle valve position sensor
UNIRAM2 CUNEEP2 UNIEEP2	1 Cam sensor
	2 Signal panel sequence
	3 EPROM
	4 EEPROM
	5 Neutral/drive signal
	6 Digimatic signal
	7 RAM memory
	8 SMOT sensor
UNIRAM3 CUNEEP3 UNIEEP3	1 0 = Maximum enrichment; 1 = Maximum leaning down
	2 0 = Air temp. sensor o.c.; 1 = Air temp. sensor s.c.
	3 0 = Water temperature sensor o.c.; 1 = Water temperature sensor s.c.
	4 0 = Throttle valve potentiometer o.c.; 1 = Throttle valve potentiometer s.c.
	5 Arrival of 6 SMOT. consecutively
	6 0 = SMOT o.c.; 1 = SMOT s.c.
	7 0 = Cam o.c.; 1 = Cam s.c.
	8 0 = Pressure sensor c.o.; 1 = Pressure sensor c.c.
UNIRAMS	1 Power ON no digimatic gear change
	2 1 = Decrease in advance for detonation, 0 = No decrease
	3 0 = Awaiting recognition of signal panel, 1 = Signal panel OK
	4 0 = Partialised, 1 = Throttle valve minimum or wide open
	5 0 = ABS not active, 1 = ABS active
	6 0 = Absence of conditioner command, 1 = Conditioner active
	7 0 = Neutral position , 1 = Drive position
	8 0 = VAE normal operation, 1 = Self-cleaning underway

4.4.4.1

ELECTRONIC KEY (Immobiliser) status/error bytes in RAM

Request from Test Instrument

The request from the Test Instrument occurs by the transmission on line "L" of the code "UNIVAS" (71H).

Response from E.C.U

The E.C.U. responds on line "K" with a " UNIVAS " byte coded as follows:

Byte	Decoding
UNIVAS	1° Virgin E.C.U.
	2° E.C.U. in " prohibit engine management "
	3° Universal code received
	4° N.U.
	5° N.U.
	6° Erroneous key code (10.10.10.10.10) transmitted by Immobiliser
	7° Unknown or not recognised code
	8° No code received or link interrupted

IMPORTANT

The ELECTRONIC KEY control unit transmits the code 10.10.10.10.10 (erroneous key) only if the engine control unit is stored. If the engine control unit is not stored, the ELECTRONIC KEY control unit will not transmit anything if there is a malfunction; The error code transmitted to the tester by the engine control unit which has not been stored is always: " code not received or link interrupted " .

4.4.4.2

ELECTRONIC KEY (Immobiliser) status/error bytes in EEPROM

Request from Test Instrument

The request by the Test Instrument occurs by transmission on line "L" of the code "EEVAS" (72H)

Response from E.C.U

The E.C.U. responds on line "K" with a " EEVAS " byte coded as follows:

Byte	Decoding
EEVAS	1° N.U.
	2° N.U.
	3° N.U.
	4° N.U.
	5° N.U.
	6° Erroneous key code (10.10.10.10.10) transmitted by immobiliser
	7° Unknown or not recognised code
	8° No code received or link interrupted

4.4.4.3

ELECTRONIC KEY (Immobiliser) error age counter in EEPROM

Request from Test Instrument

The request by the Test Instrument occurs by transmission on line "L" of the code " CRDVAS " (73H)

The " CRDVAS " counter is initialised at FFH when an error is detected.

It is decreased at each KEY-ON when no errors are present.

When the " CRDVAS " counter reaches zero, the contents of the " EEVAS " are erased.

4.4.5

Transmission of the secret code

The code is recognised by the owner of each vehicle and is written on the " Security Card " given to the client together with the keys.

To actuate the recovery procedure with the Test Instrument, type in the code on the keypad of the tester starting from the first digit on the left.

To transmit the secret code to the E.C.U. the Test Instrument must enter active diagnosis.

The exchange of data between the ECU and the Test Instrument is shown in the following table

Transmission of the code by the Test Instrument

N	REQUEST	CODE	RESPONSE
1	Entry into active diagnosis ●	AAH ●	ECHO
2	Code for start of test	98H	ECHO
3	1st digit	0XH	ECHO
4	2nd digit	0XH	ECHO
5	3rd digit	0XH	ECHO
6	4th digit	0XH	ECHO
7	5th digit	0XH	ECHO
8	Code for end of test	FFH	ECHO
9	End of active diagnosis ●	FFH ●	ECHO

● **The codes for the start and end of active diagnosis (AAH and FFH) need not be sent for all the applications preceding W4 PSP i.e. all those with ISO code : 55h B3h 80h XXh XXh XXh**

For reasons of safety, the ECU does not confirm if the code received is correct:

The only way of checking is by starting the vehicle.

End of diagnosis dialogue

Switching off the engine.

4.5

Active diagnosis

4.5.1

Active diagnosis mode**Method of entering active diagnosis.**

– By transmission of a byte (**AAh**) with ignition ON and engine OFF.

Acknowledge by E.C.U. following a request for entry into active diagnosis :

– Echo of command transmitted

Test methods in active diagnosis.

– The control unit prevents the engine from being started apart from the case of Mixture ratio Regulation and Self–adaptation Memorisation.

Behaviour of control unit during active diagnosis :

– The data is continually updated.

Result of test at end of diagnosis.

– Test with positive result : Transmission of a byte at **FFh**.

– Test with negative result : Transmission of a byte at **EEh**.

Method of interrupting activation of a device.

– By the transmission of a byte : **FFh**.

Erasing the error memory.

– Sending the code **86h** in active diagnosis environment.

Exiting active diagnosis :

– By transmission of a byte : **FFh**.

4.5.2

Time schedule

4.5.2.1

Devices which can be activated

Activation byte value (Hex.)	Device	State of vehicle	Activation mode or Max. Time
80	Fuel pump	Key ON	ON for 30s
81	Injectors in sequence		ON for 2ms every second for 5 times
82	Power module 1		ON for 2ms every second for 5 times
83	VAE		ON for 25ms, OFF for 25ms for 5s
84	Overboost (only for T/C)		ON for 131ms, OFF for 131ms for 5s
85	Power module 2		ON for 2ms every second for 5 times
86	Error deletion		
87	TRIMRAM management	Engine RUN	For CO regulation algorithm see paragraph 4.5.6
88	Computer trip command	Key ON	ON for 10s at 125Hz (25 l/h)
89	Rev counter		ON for 2s at 125Hz (3750 RPM)
8A	TRIMRAM Entry pre-code		
8C	Injector 1		ON for 2ms. every second for 5 times
8D	Injector 3		
8E	Injector 4		
8F	Injector 2		
90	Canister		ON for 20ms every second for 7 times
9B	End of TRIMRAM calibration	Engine RUN	For CO regulation algorithm see paragraph 4.5.6
92	Self-adaptation parameters memorisation pre-code	Key ON	For self-adaptation parameters memorisation algorithm, see paragraph 4.5.7
93	Memorisation of self-adaptation parameters	Engine RUN	
FF	End of active diagnosis/ deactivation of test underway	Key ON / Engine Running	
91	Deactivation of mixture ratio self-adaptation	Key ON	

4.5.3

Air/Water conversion table.

Air / Water	Bit	0	16	32	48	64	80	96	112	128	144	60
Equivalent Temp.	Degrees	125			78.6	59.2	47.5	37.9	29.5	22.0	14.0	6.2
Air / Water	Bit	176	192	208	224	240						
Equivalent Temp.	Degrees	-1.8	-11.8	-28.7	-55							

4.5.4

Treatment of the errors

As soon as an error is detected an initial period of filtering is activated after which the error is checked to see if it is still present; if the bit relative to the error is set in the UNIRAM and the last value read is held to be valid.

After memorisation in the UNIRAM another period of filtering is activated after which the error is checked once again to see if it is still present; if the error is no longer present the bit set previously in the UNIRAM is reset, if the error is still present the bits relative to the CUNEPP and UNIEEP words are set; in addition to this the malfunction warning light is lit and the age counter of the erroneous line is initialised at a calibrated value.

If, following this the error disappears, this counter is decreased by 1 each time the vehicle is started with a successive period without failures occurring. At the same time the warning light is switched off. When the counter reaches 0, the failure is deleted from the EEPROM permanent memory.

If the error re-appears, the counter is once again set to the maximum value.

Some errors cannot wait for the filtering time due to the lack of cyclic monitoring so that the detection implies an immediate memorisation in all the registers and an updating of the counter; in this case the warning light does not stay on for the entire time the error persists but only for a time defined by calibration (e.g. 20 s).

4.5.5

Active diagnosis test flow chart.

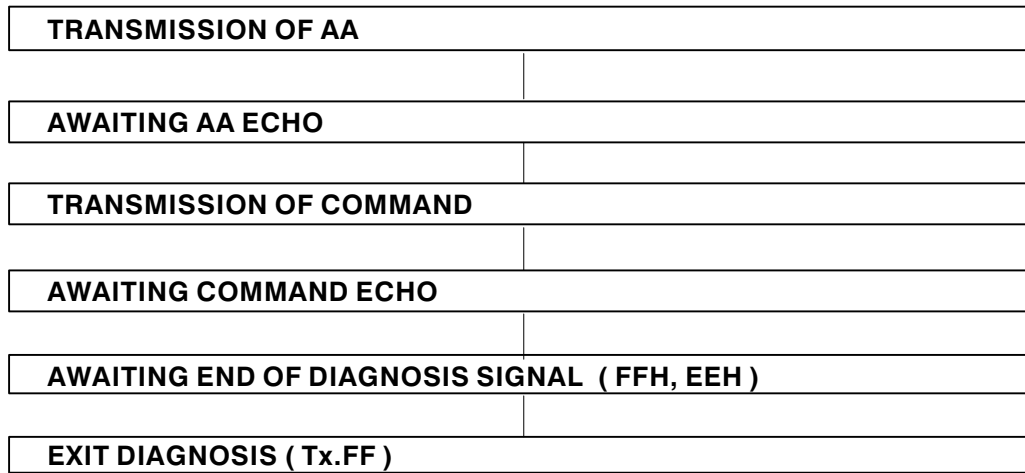

4.5.6

CO regulation flow chart

ENGINE OFF

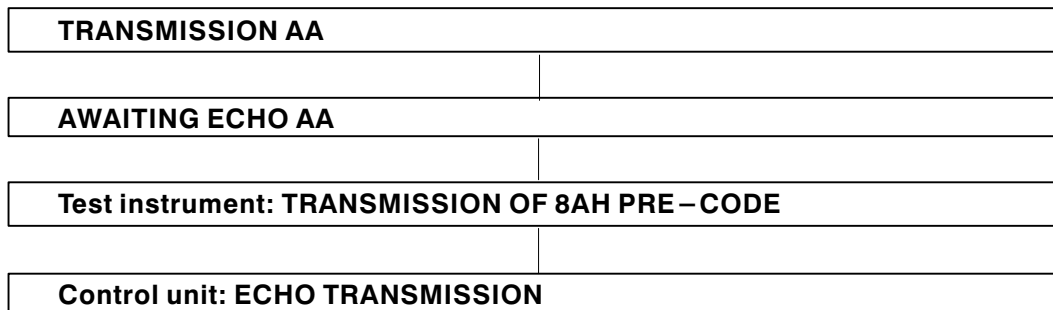

CARTA RICICLATA 100% 100% RECYCLED PAPER

CONFIDENTIAL
THIS DOCUMENT MUST NOT BE REPRODUCED OR CIRCULATED TO THE THIRD PARTIES
WITHOUT PRIOR WRITTEN CONSENT BY FIAT AUTO S.P.A. IN CASE OF DISPUTE
THE ONLY VALID REFERENCE IS THE ORIGINAL ITALIAN EDITION

ENGINE ON

Test instrument : TRANSMISSION OF CODE 87H

Control unit : CODE ECHO

Test instrument : TRANSMISSION OF NEW TRIMRAM VALUE

Control unit : ECHO OF NEW TRIMRAM VALUE

Test instrument : TRANSMISSION OF FFH CODE

Control unit : ECHO

Test instrument : 8BH MEMORISATION CODE

Control unit : ECHO

Note : If the CO regulation is concluded with the transmission of the code **8Bh**, the final value of TRIMRAM sent to the control unit will be stored in the E2PROM , if the vehicle is switched off without code **8Bh** being sent, the last TRIMRAM value sent will not be used.

4.5.7

Self-adaptation parameters memorisation flow chart

ENGINE OFF

TRANSMISSION AA

AWAITING AA ECHO

Test instrument : TRANSMISSION OF 92H PRE-CODE

Central unit : TRANSMISSION OF ECHO

ENGINE ON

Awaiting attainment of optimal running temp.

Test instrument : transmission of 93H self-adaptation parameters memorization code

Central unit : ECHO CODE + FFH BYTE TRANSMISSION

Note : If the self-adaptation parameters regulation is concluded with the transmission of the code **93h**, the final value sent to the control unit will be stored in the E2PROM , if the vehicle is switched off without the code **93h** being transmitted, the last value sent will not be used.